

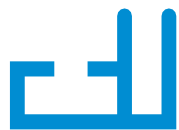

ELTEX PROFILES

2019 CATALOGUE

ELTEX PROFILES
2019 CATALOGUE



eltex 16 p.6



eltex 30 p.8



eltex 40s p.10



eltex 40 p.12

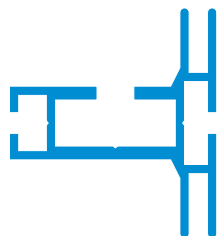

eltex 50 p.14

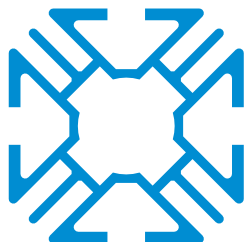

eltex cube p.16

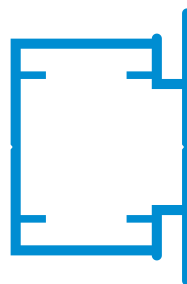

eltex 55EF p.18

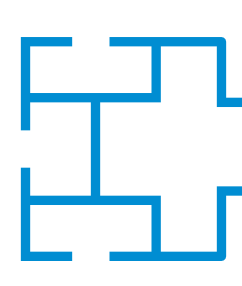

eltex magnetic p.20



eltex 60S p.22



eltex 80S p.24



eltex 80EF p.26



eltex 82 p.28



eltex 100S p.30



eltex 100D p.32



eltex 122 p.34



eltex 150S p.36



eltex 150D p.38



eltex 200 p.40



eltex cover p.42

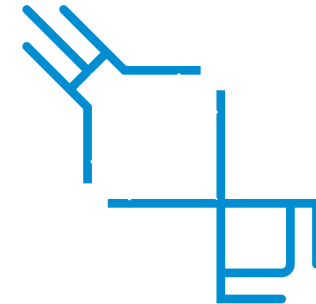

edge & corner p.44



keder 38/16 p.46

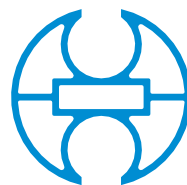

keder Ø32 p.48

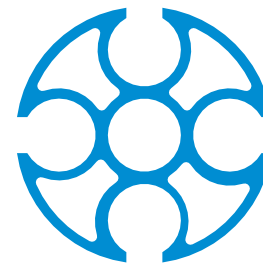

keder Ø50 p.49

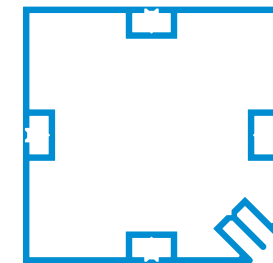

MX 80 Edge p.50





ELTEX 16

This single-sided profile is widely used in retail & expo areas especially integrated into exhibition booths. Frames can be easily wall-mounted and dimensions can be customized.

MATERIAL:
ALUMINUM ANODISED

COLOR:
NATURAL OR RAL

WEIGHT:
0,35 KG/R.M.

CATALOGUE NO.:
04.001



fabric





ELTEX 30

This single-sided profile is very popular and can be mounted to the wall or suspended from the ceiling. It is available in anodised version or in any colour according to the RAL palette. The profile is designed for arrangement and decoration of both expo and retail spaces.

MATERIAL:

ALUMINUM ANODISED

COLOR:

NATURAL OR RAL

WEIGHT:

0,66 KG/R.M.

CATALOGUE NO.:

04.002



fabric



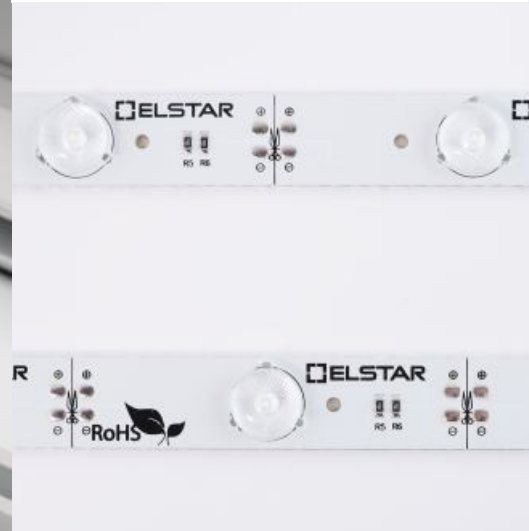

ELTEX 40S

This single-sided profile can be mounted to the wall or suspended from the ceiling. One-sided frames with printed graphics and LED illumination inside, can be successfully implemented in retail store displays, offices, hotels, restaurants, showrooms etc.

MATERIAL:
ALUMINUM ANODISED

COLOR:
NATURAL OR RAL

WEIGHT:
0,53 KG/R.M.

CATALOGUE NO.:
04.003

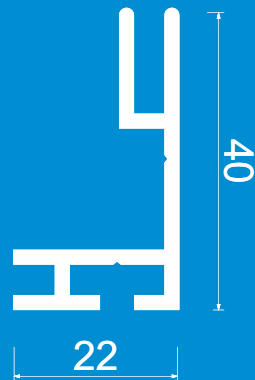

backlit



fabric





ELTEX 40

The double-sided profile can be formed in circles, ellipses etc. Available in any colour according to the RAL palette. It is widely used in retail sector or can be implemented creatively in offices, showrooms or homes.

MATERIAL:
ALUMINUM ANODISED

COLOR:
NATURAL OR RAL

WEIGHT:
0,58 KG/R.M.

CATALOGUE NO.:
04.004

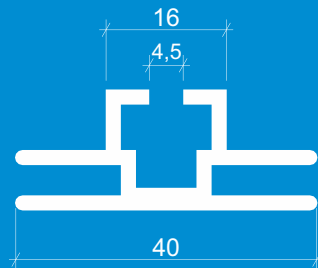

fabric





ELTEX 50

This double-sided profile is a perfect product for creating huge hanging, but still stable constructions. Eltex 50 enables you to create large frames of unlimited size straight or bent! When used suspended, this double-sided frame is frequently used to build unique banners at exhibitions above the booth or in retail signage.

MATERIAL:
ALUMINUM ANODISED

COLOR:
NATURAL OR RAL

WEIGHT:
1,14 KG/R.M.

CATALOGUE NO.:
04.005

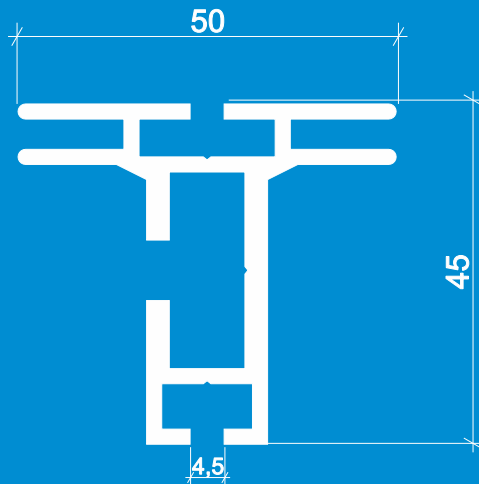

fabric

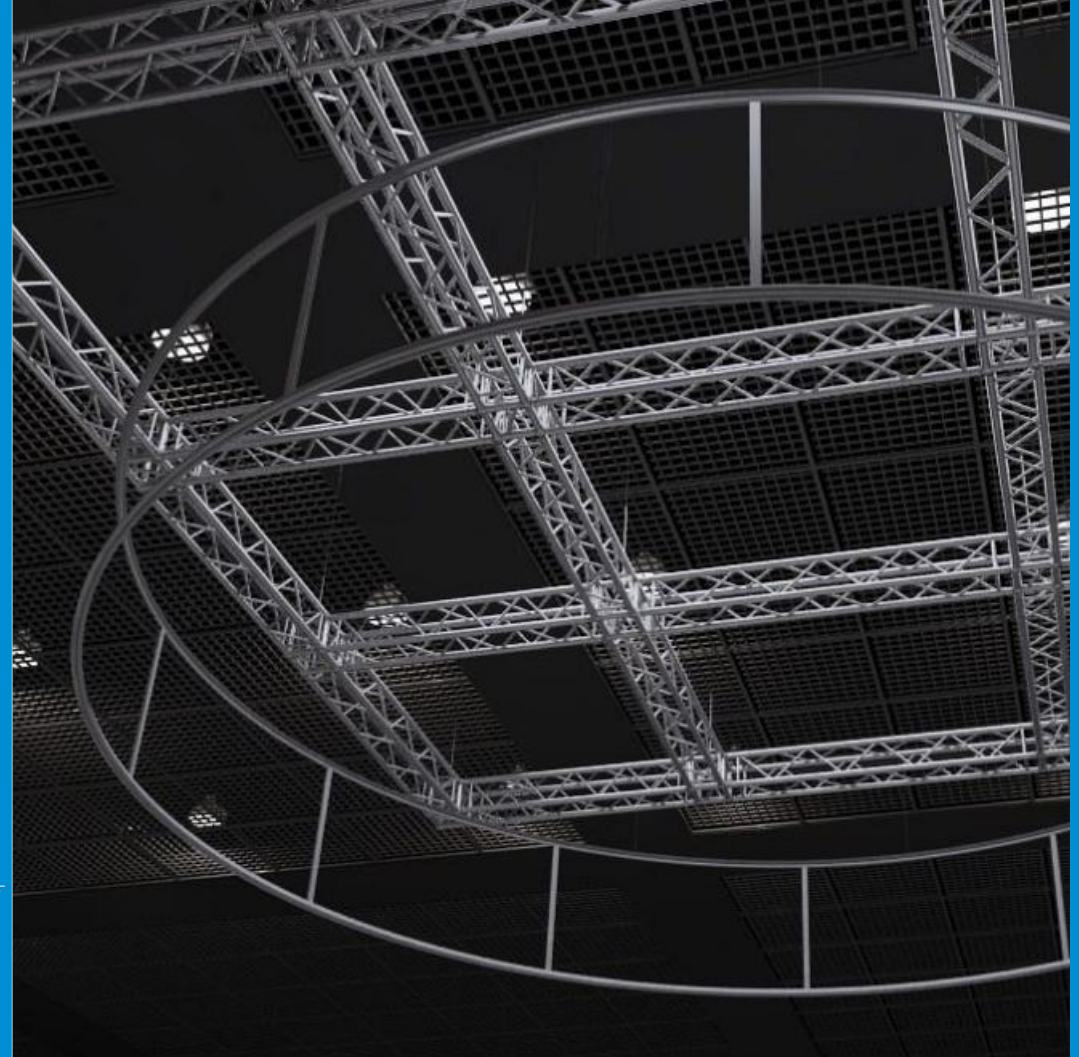



ELTEX CUBE

Due to its designed shape, it is characterized by exceptional stability and resistance. It can therefore be safely used for enormous constructions of both fair stands and suspended structures. What is more, you can present the textile print on all sides! The creation of forms such as cubes or columns is a perfect promotional device on fairs but also in public areas: airports, shopping centers, museums etc.

MATERIAL:
ALUMINUM ANODISED

COLOR:
NATURAL OR RAL

WEIGHT:
2,01 KG/R.M.

CATALOGUE NO.:
04.006

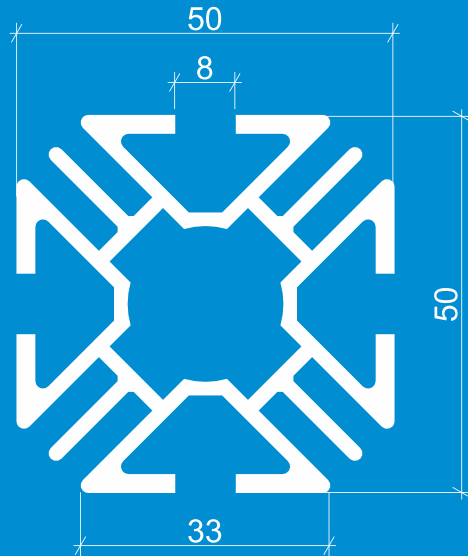

fabric





ELTEX 55EF

The double-sided profiles with holes around created for strong aluminum modular frames especially for the exhibition industry. The frame is only 55 mm thick and matches both fabric and panel (PVC, dibond) on both sides of the profiles. A wide range of accessories for customers' comfort available.

MATERIAL:
ALUMINUM ANODISED

COLOR:
NATURAL OR RAL

WEIGHT:
1,05 KG/R.M.

CATALOGUE NO.:
04.007

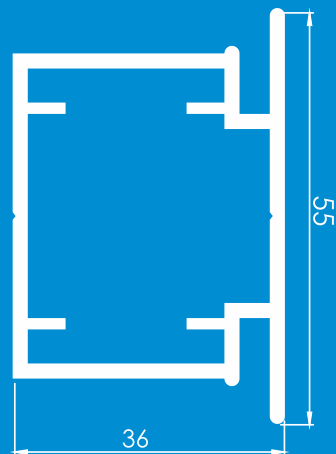

fabric



PVC/Dibond

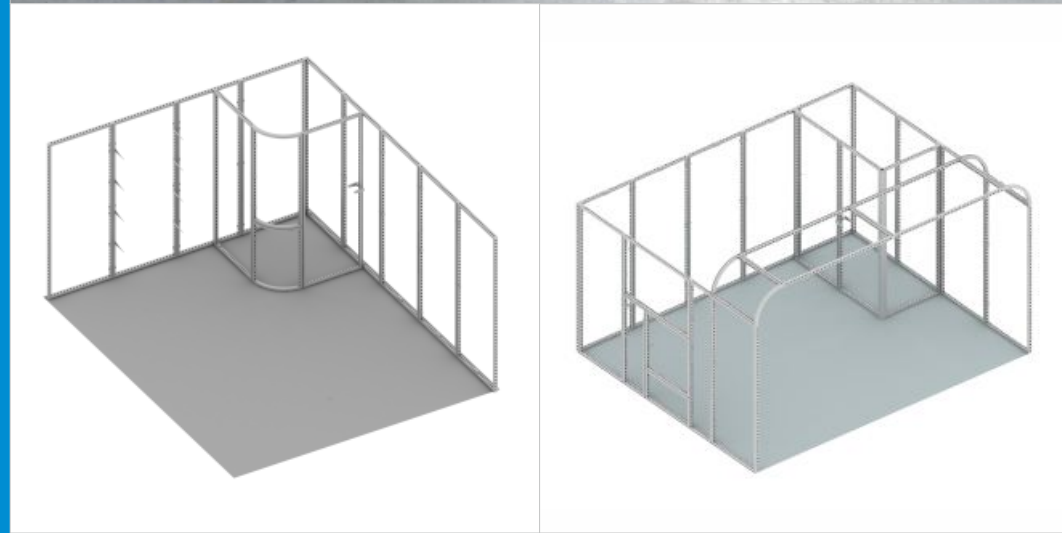
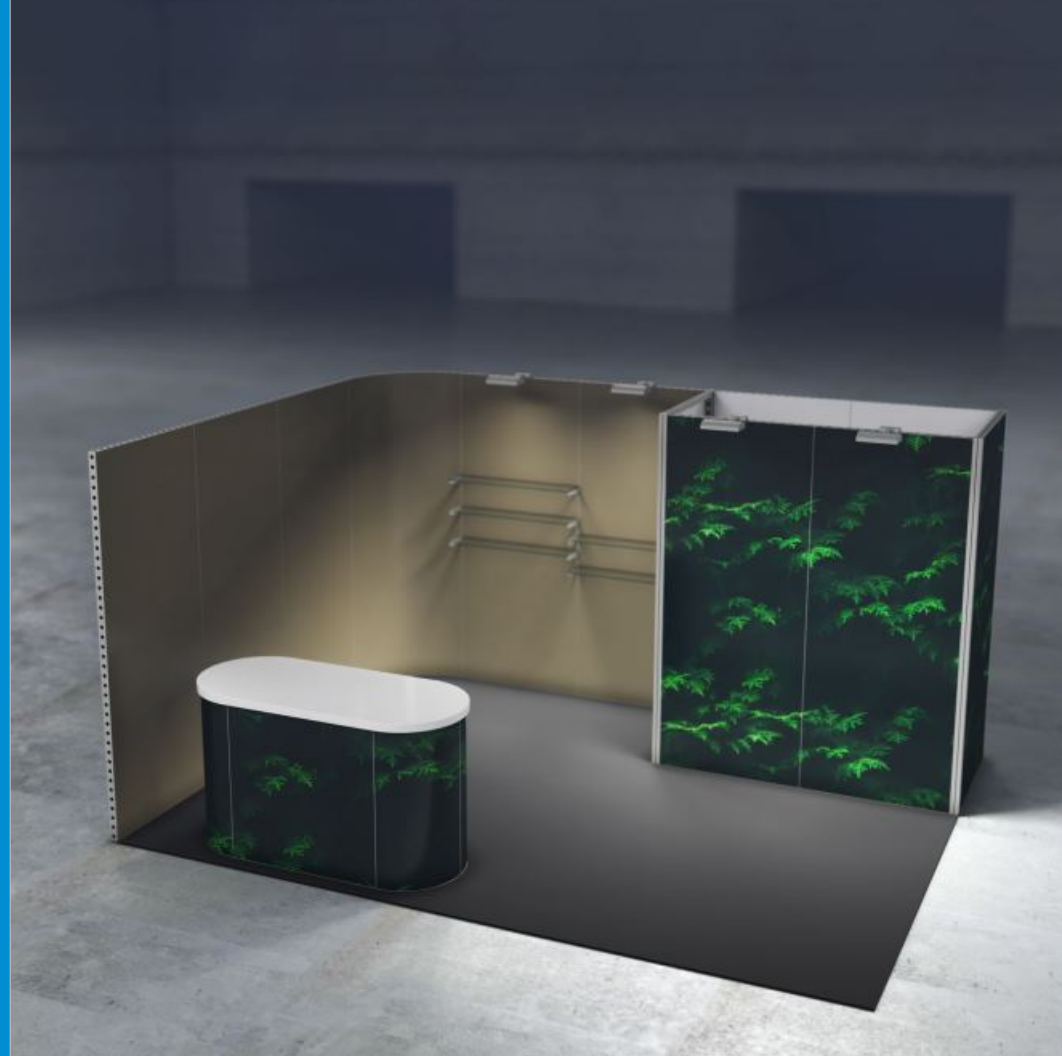

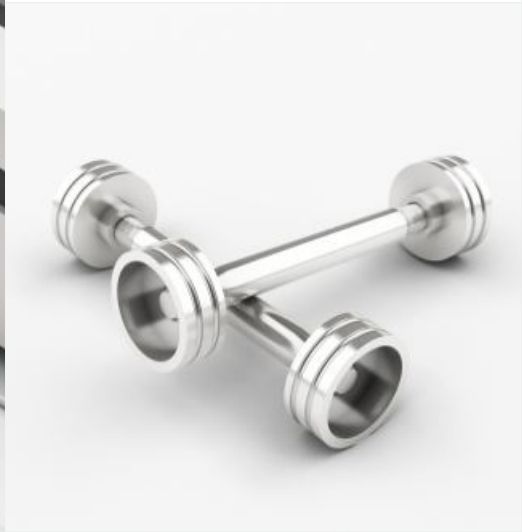

ELTEX MAGNETIC

This double-sided profile finds application in the construction of fair stands and exhibition walls. This system is extremely versatile, as it allows for presentation of graphics on printed fabric materials, PVC panels or dibond. Moreover, it is a safe and reliable profile for creating modular stands.

MATERIAL:
ALUMINUM ANODISED

COLOR:
NATURAL OR RAL

WEIGHT:
1,61 KG/R.M.

CATALOGUE NO.:
04.008

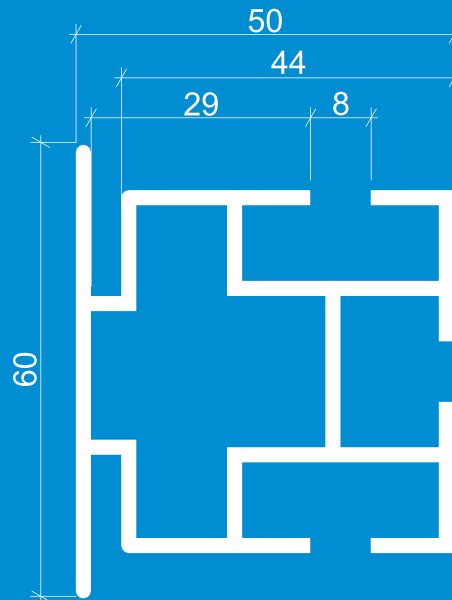

fabric



PVC/Dibond

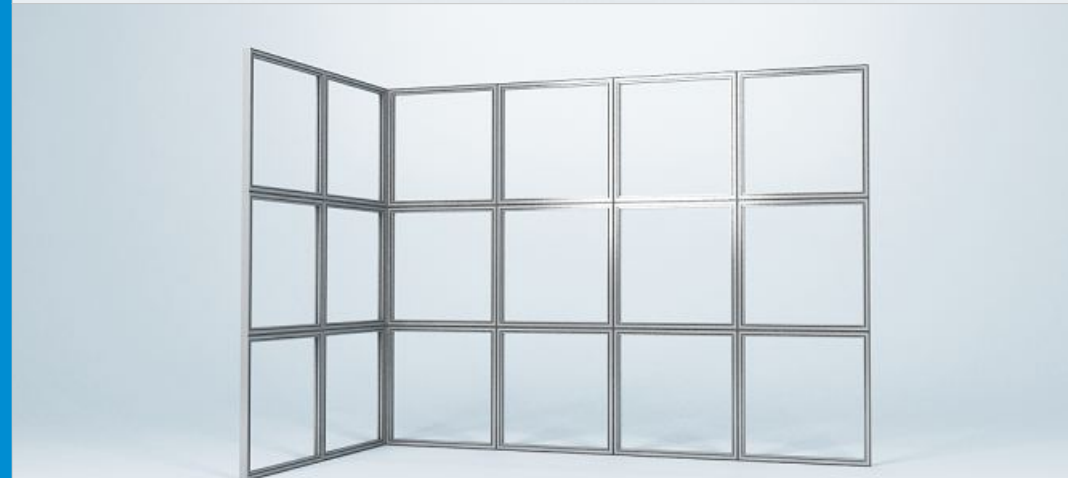



ELTEX 60S

The single-sided profile can be successfully used while creating exhibition and store spaces. One-sided frames with printed graphics are decorative and very remarkable elements of such interiors as hotels, offices, showrooms, shops and restaurants. The Lightbox frames with graphics illuminated from back using LED strips on a back with a depth of only 60 mm, are a frequent decoration in retail store displays.

MATERIAL:
ALUMINUM ANODISED

COLOR:
NATURAL OR RAL

WEIGHT:
0,75 KG/R.M.

CATALOGUE NO.:
04.009



backlit



fabric

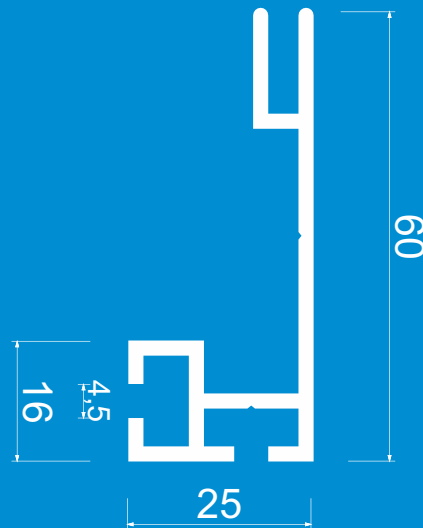

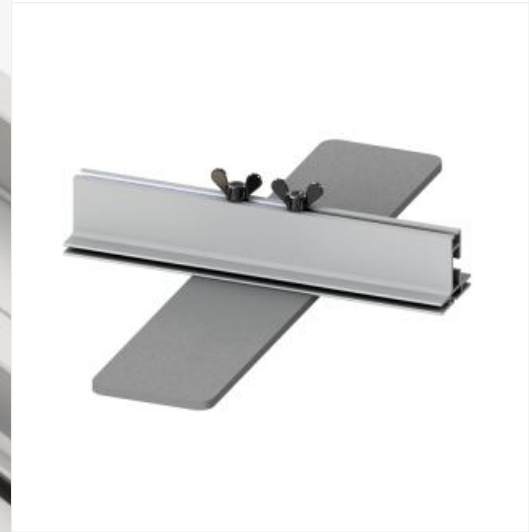

ELTEX 80S

This single-sided profile can be successfully used while creating exhibition and store spaces. Moreover, the profile is compatible with our MX System and Easy Frames, that is why the booth built on the basis of the both systems is uniquely modern.

MATERIAL:
ALUMINUM ANODISED

COLOR:
NATURAL OR RAL

WEIGHT:
1,34 KG/R.M.

CATALOGUE NO.:
04.010

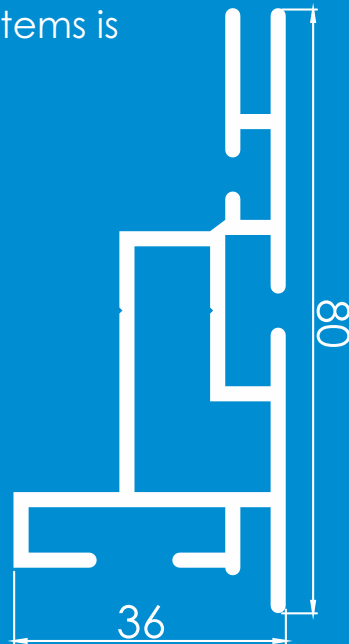

backlit



fabric





ELTEX 80EF

The double-sided profiles with holes around created for strong aluminum modular frames, especially for the exhibition industry. The family product of Eltex 55 EF. This one is 80 mm thick and matches also both fabric and panel (PVC, dibond) on both sides of the profiles. A wide range of accessories for customers' comfort available.

MATERIAL:
ALUMINUM ANODISED

COLOR:
NATURAL OR RAL

WEIGHT:
1,34 KG/R.M.

CATALOGUE NO.:
04.011



fabric



PVC/Dibond

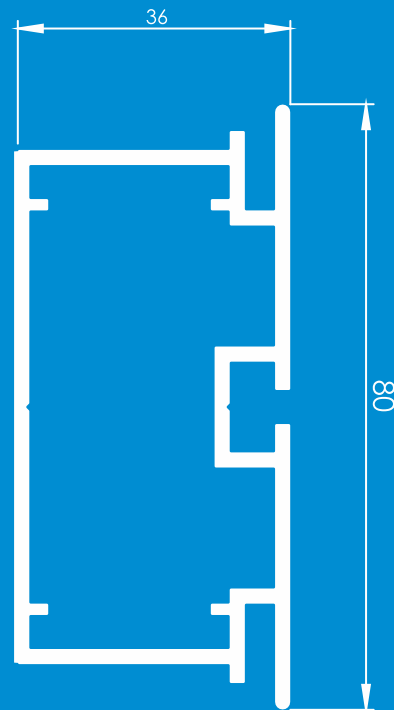



ELTEX 82

With this double-sided profile you can build a strong aluminum frame. Spatial cubes made of Eltex 82 are very impressive elements of each fair stand or promotional area. Moreover, illuminating the construction makes it very distinguishable.

MATERIAL:
ALUMINUM ANODISED

COLOR:
NATURAL OR RAL

WEIGHT:
1,26 KG/R.M.

CATALOGUE NO.:
04.012

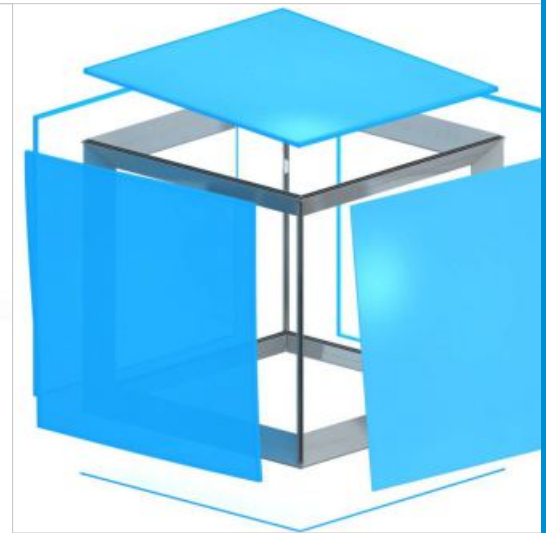
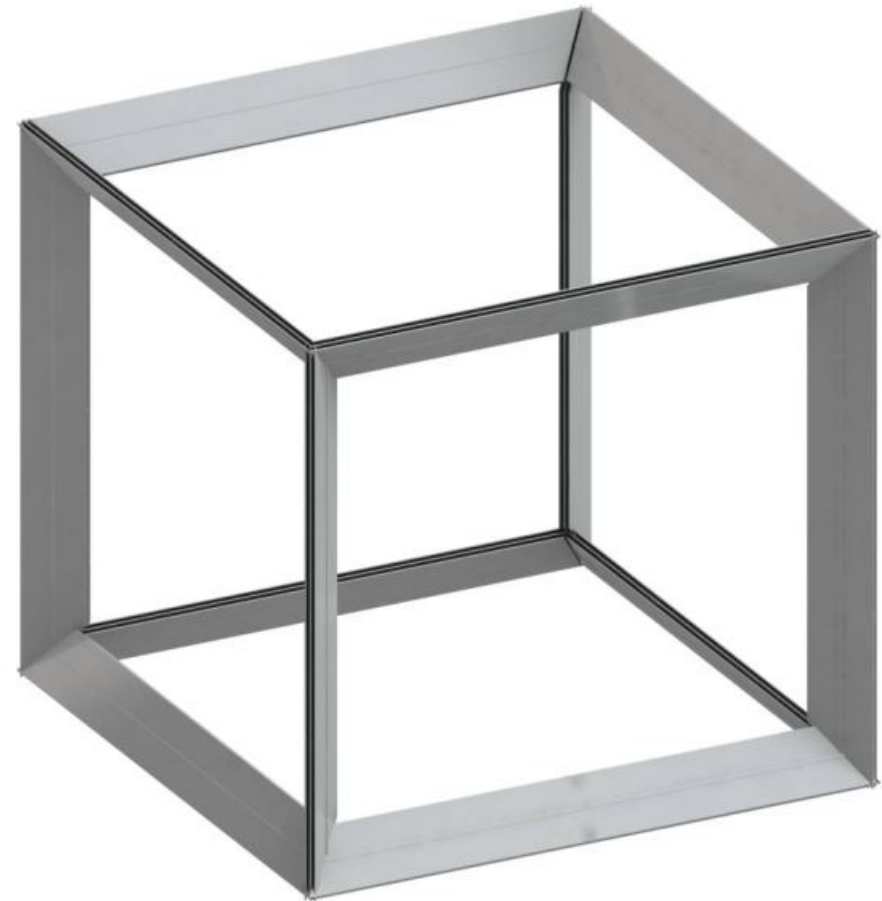

backlit



fabric



ELTEX 100S

The single-sided profile can be successfully applied for wall-mounted illuminated frames or free-standing lightboxes. This profile is very frequently used in expo and retail sector.

MATERIAL:

ALUMINUM ANODISED

COLOR:

NATURAL OR RAL

WEIGHT:

1,02 KG/R.M.

CATALOGUE NO.:

04.014

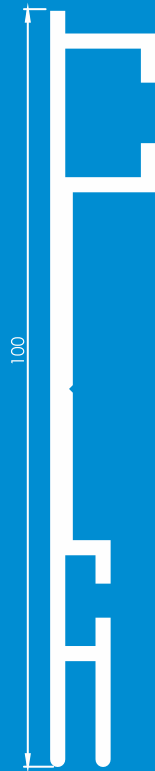

backlit



fabric





ELTEX 100D

This double-sided profile is specially designed for illuminated free-standing or free-hanging frames. Illumination is provided by LED stripes mounted to the inside channel of the frame. Applying LED lights enhances the aesthetic values of all graphics, which results in perfect presentation of your advertisement.

MATERIAL:
ALUMINUM ANODISED

COLOR:
NATURAL OR RAL

WEIGHT:
1,3 KG/R.M.

CATALOGUE NO.:
04.015



backlit



fabric





ELTEX 122

This double-sided profile is another innovative profile of the system, which together with compatible square profiles from MX system allows you to build large-scale fair stands. Ideal for freestanding exhibition walls or free-hanging banner in extreme sizes. Illuminated wall made of printed fabric greatly increases the visual aspects of a structure.

MATERIAL:

ALUMINUM ANODISED

COLOR:

NATURAL OR RAL

WEIGHT:

1,8 KG/R.M.

CATALOGUE NO.:

04.016



backlit



fabric

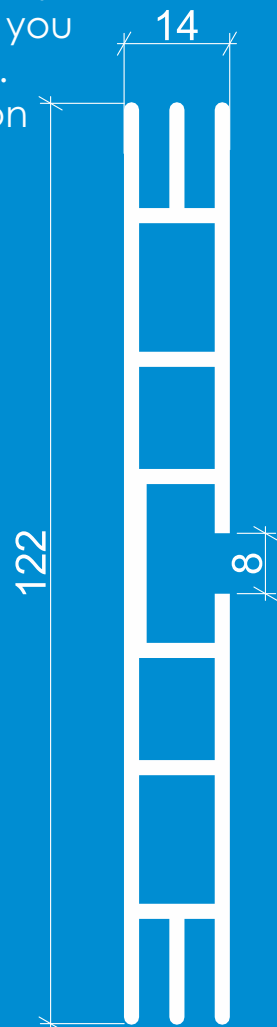

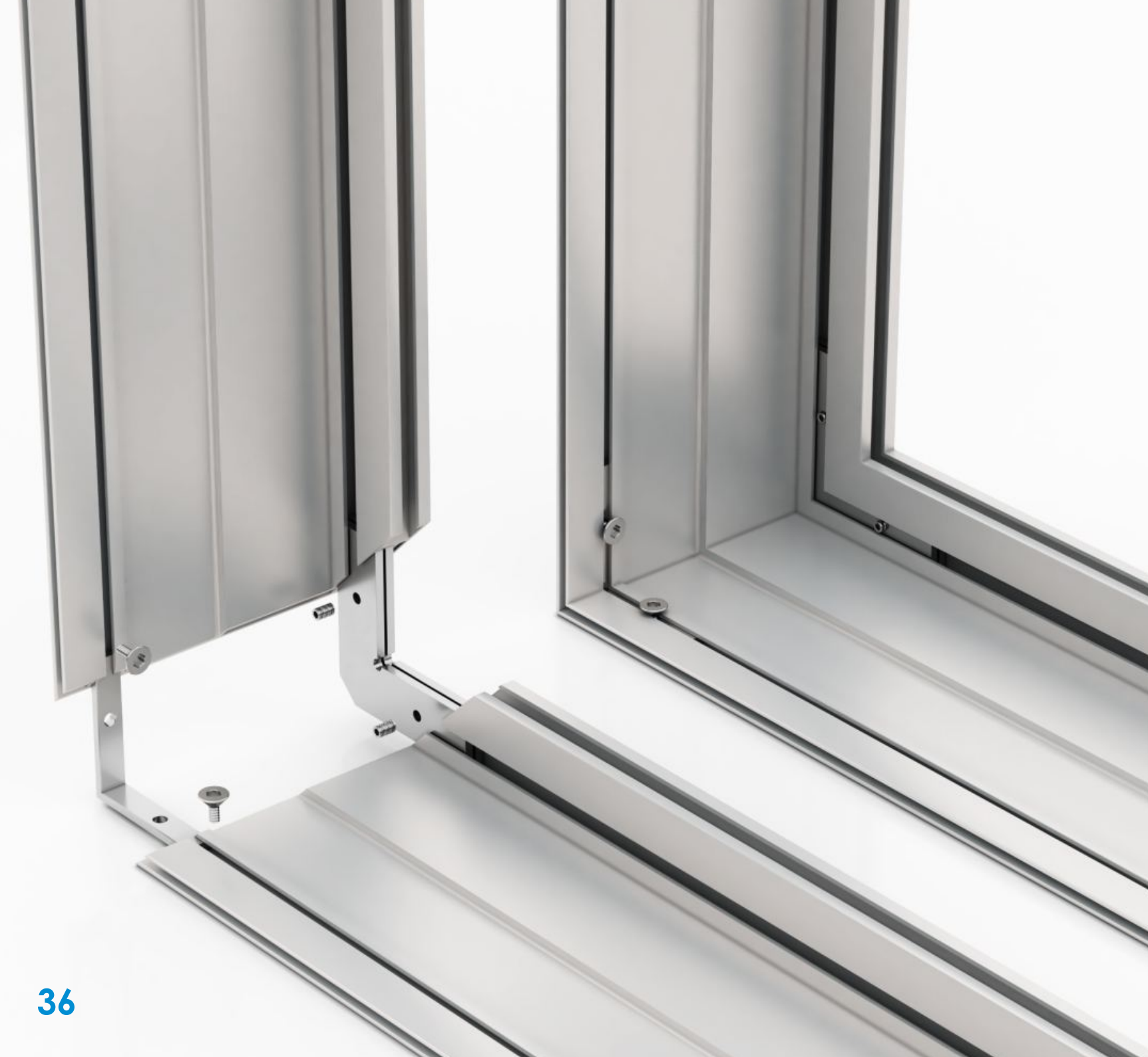

ELTEX 150S

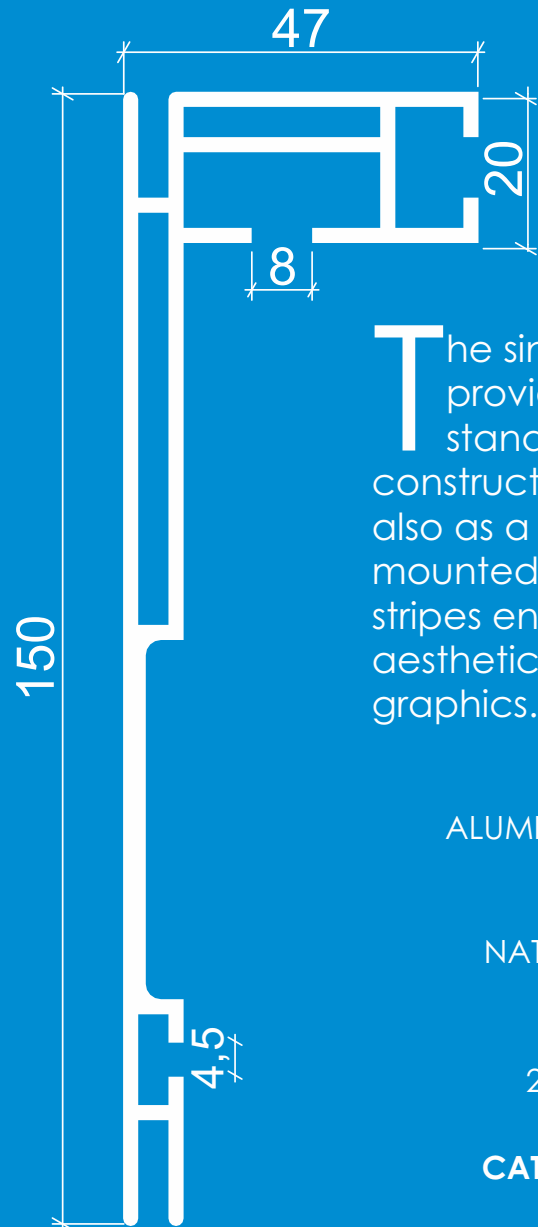

backlit



fabric

The single-sided profile provides stability for free-standing booth constructions. It can be used also as a free-hanging or wall mounted frame. Applying LED stripes enhances the aesthetic values of all graphics.

MATERIAL:
ALUMINUM ANODISED

COLOR:
NATURAL OR RAL

WEIGHT:
2,2 KG/R.M.

CATALOGUE NO.:
04.017





ELTEX 150D

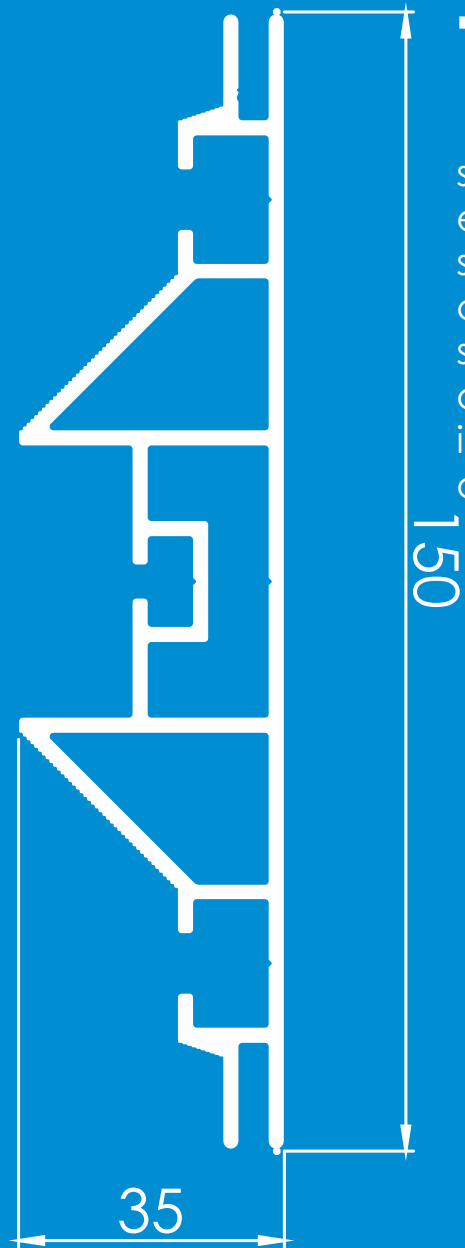

These double-sided frames made of eltex 150 D are used as free-standing or suspended elements. Ideal for free-standing, illuminated booth construction in enormous sizes. Illuminated wall made of printed fabric greatly increases the visual aspects of a construction.

MATERIAL:
ALUMINUM ANODISED

COLOR:
NATURAL OR RAL

WEIGHT:
2,35 KG/R.M.

CATALOGUE NO.:
04.018



backlit



fabric





ELTEX 200

The most stable, double-sided profile has been designed to create even huge, impressive displays structures. Perfect for illumination with graphics on both sides. Illumination is provided by LED stripes mounted inside to the channel of the frame. The constructions draw attention and maximize extraordinary, visual impressions!

MATERIAL:
ALUMINUM ANODISED

COLOR:
NATURAL OR RAL

WEIGHT:
3,35 KG/R.M.

CATALOGUE NO.:
04.019



backlit



fabric

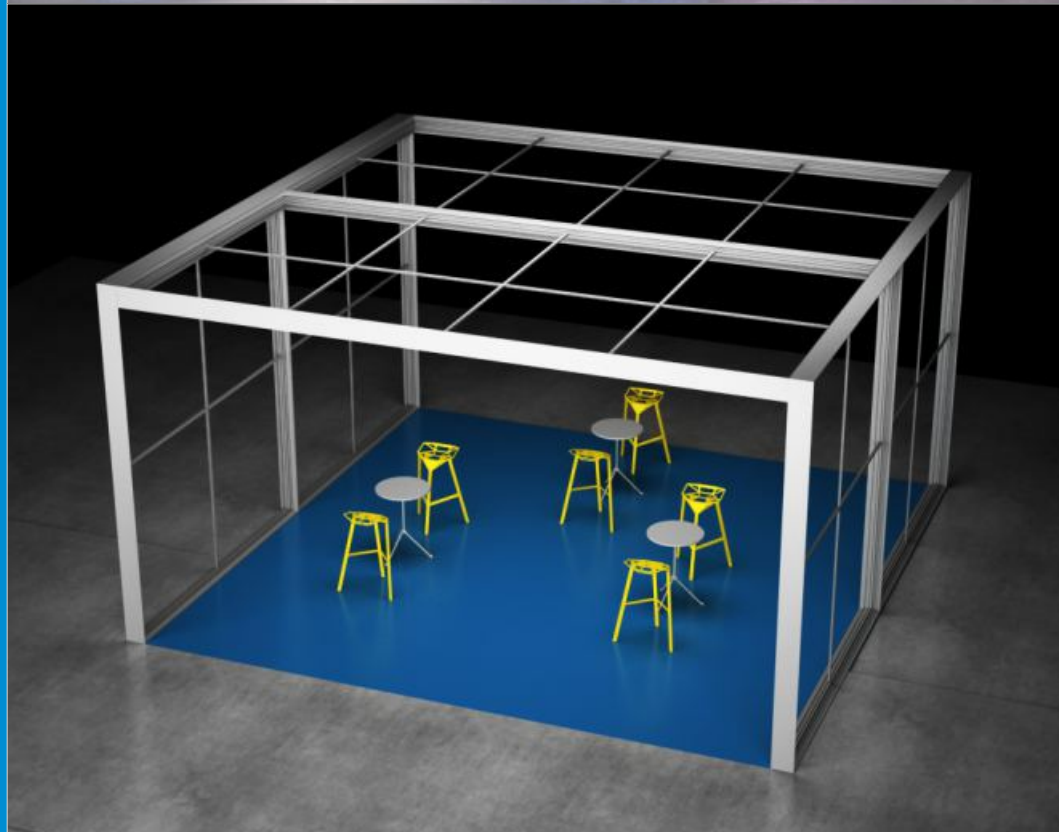
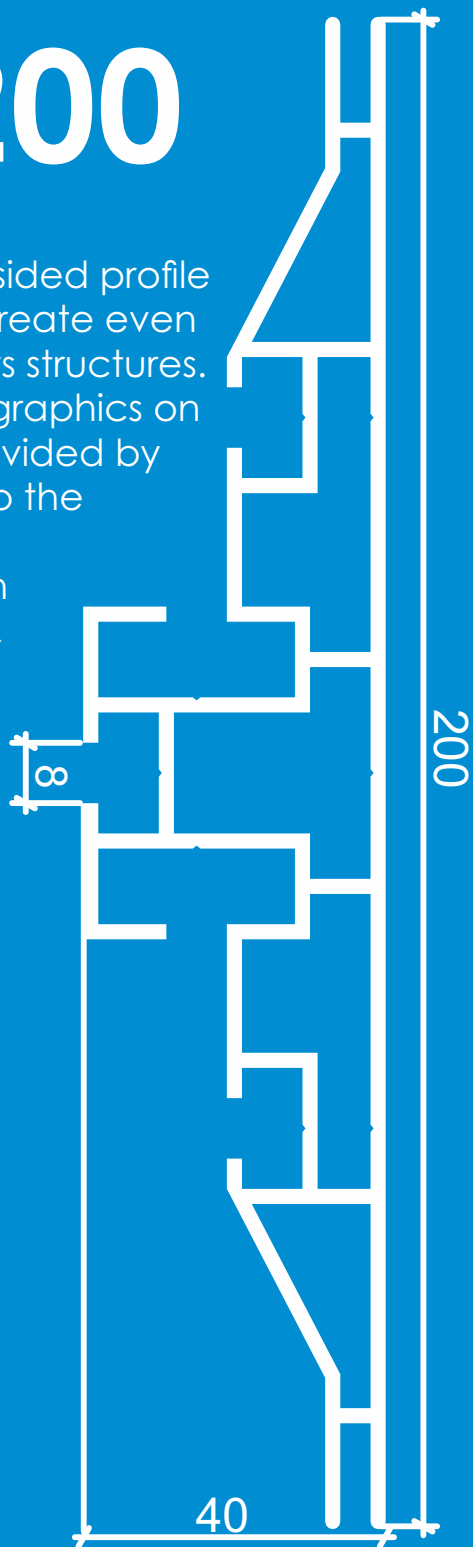

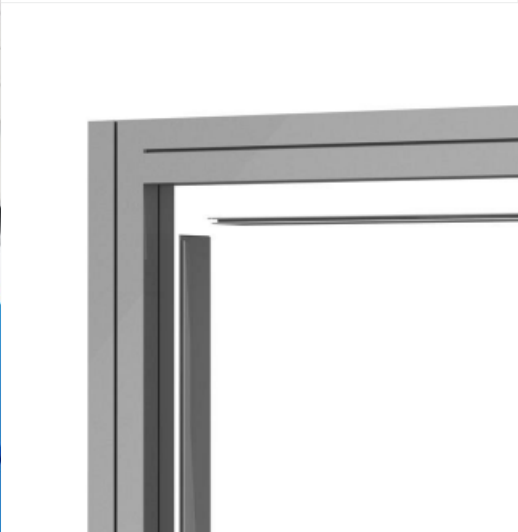

ELTEX COVER

Applying Eltex cover profiles creates the opportunity of building a unitary textile wall combined with classic MX construction. Furthermore, the wall can be illuminated by using LED strips, which makes it very outstanding.

MATERIAL:

ALUMINUM ANODISED

COLOR:

NATURAL OR RAL

WEIGHT:

0,53 KG/R.M.

CATALOGUE NO.:

04.020

80



fabric



ELTEX EDGE

This profile has a perfect application when screening profiles is necessary. Fixing Eltex EDGE profiles to the outer corner on the MX stand construction helps to build very modern stand with textile walls.

MATERIAL:
ALUMINUM ANODISED

COLOR:
NATURAL OR RAL

WEIGHT:
0,57 KG/R.M.

CATALOGUE NO.:
04.021

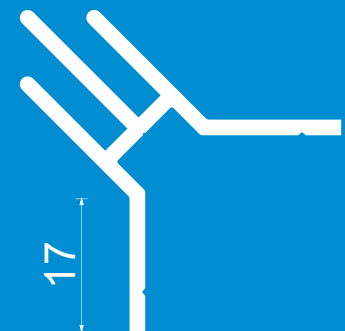

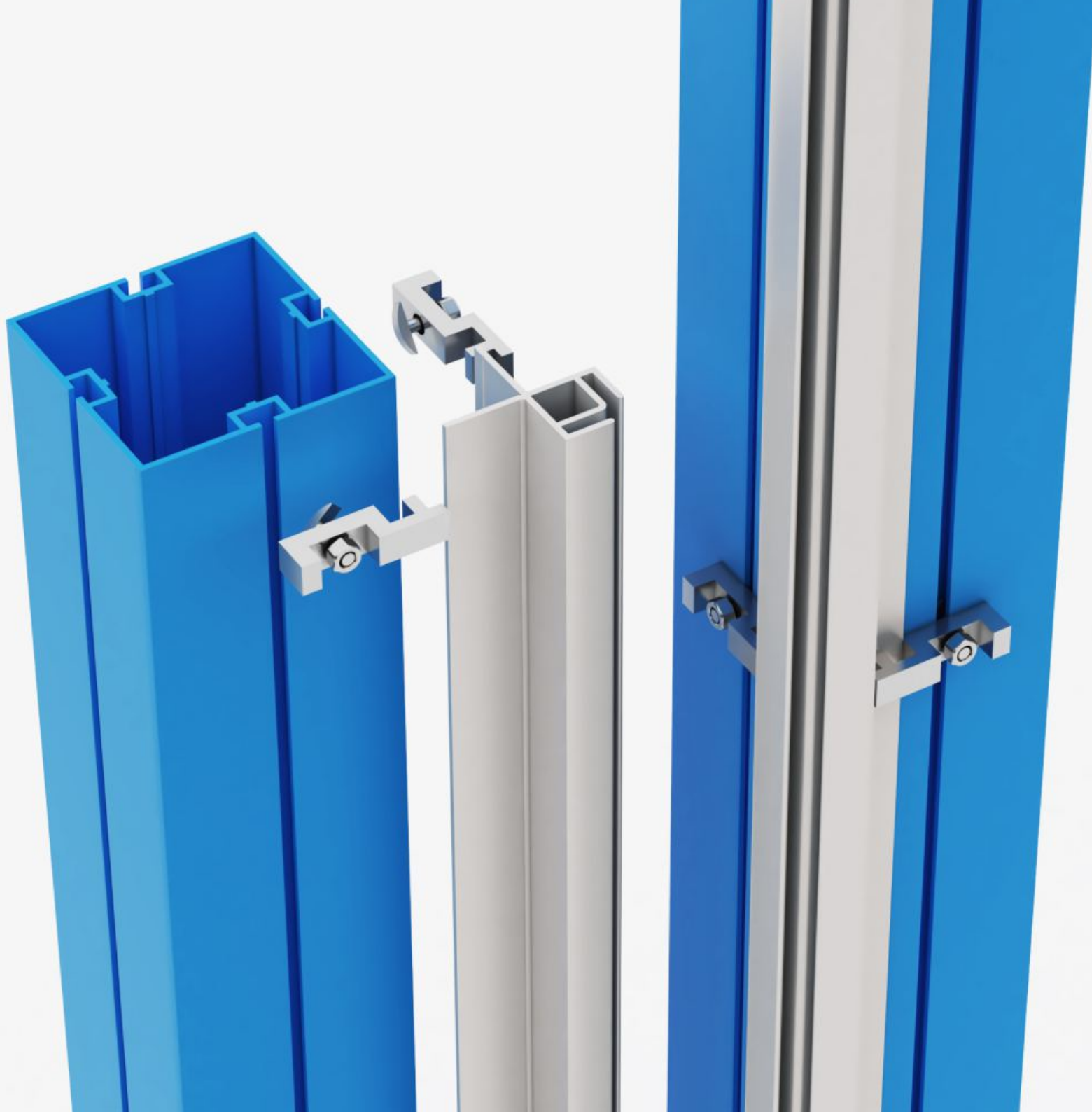

ELTEX CORNER

The main function of the profile is setting up the MX stand construction combined with Eltex profiles which consequently results in a total transformation of traditional system in very modern stand.

MATERIAL:
ALUMINUM ANODISED

COLOR:
NATURAL OR RAL

WEIGHT:
0,82 KG/R.M.

CATALOGUE NO.:
04.022 25

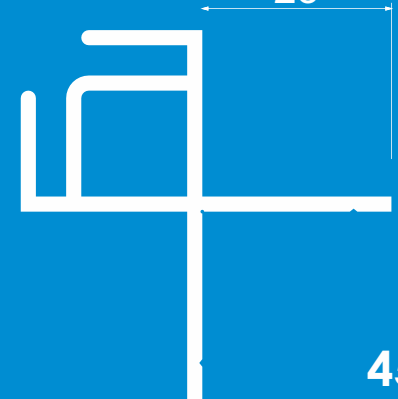

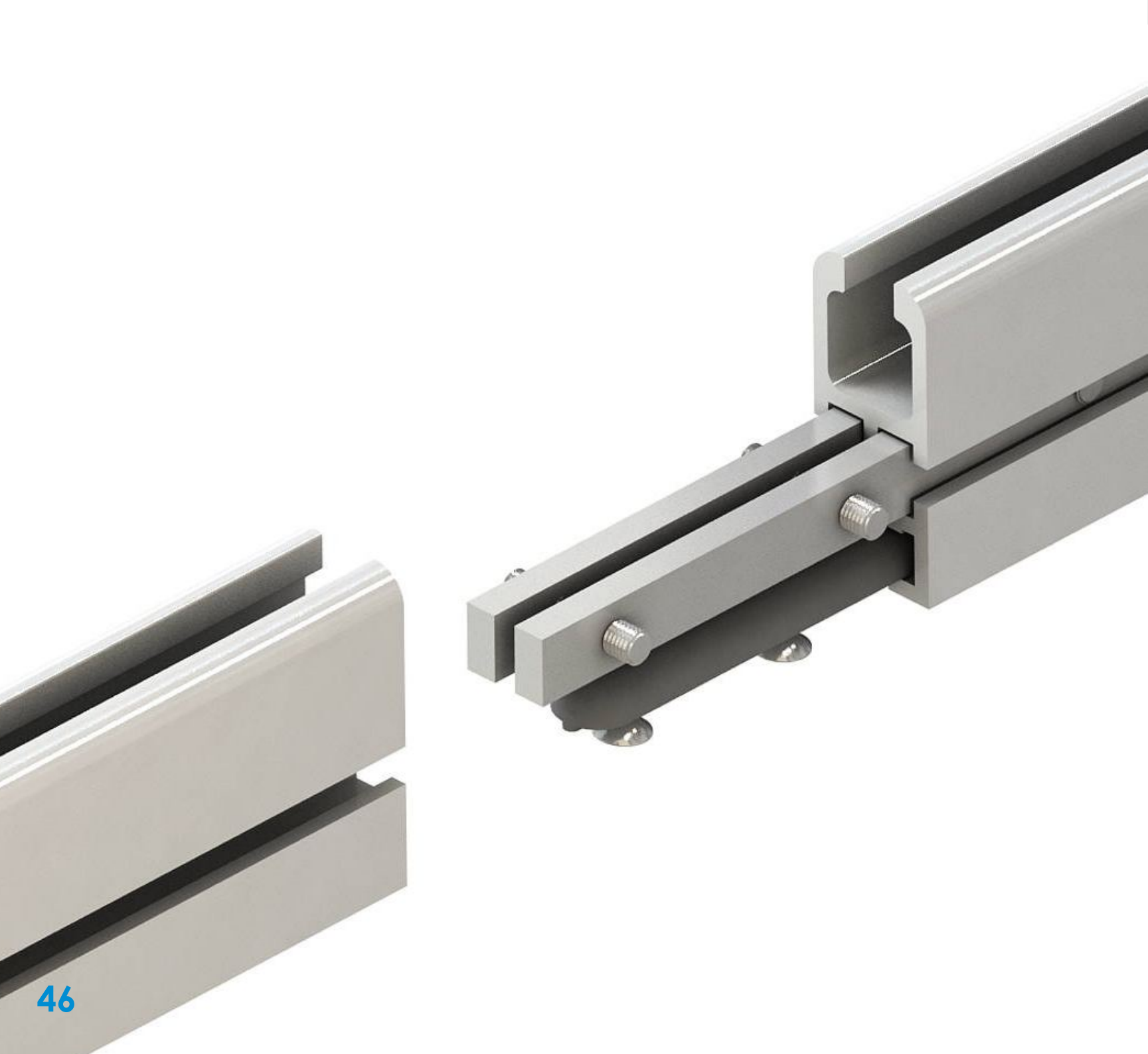

ELTEX

KEDER 38/16

The Profile is used to make straight and curved forms. Graphics printed on fabric spread between profiles combined with the strut system provide perfect tension of material.

MATERIAL:
ALUMINUM ANODISED

COLOR:
NATURAL OR RAL

WEIGHT:
0,7 KG/R.M.

CATALOGUE NO.:
04.023

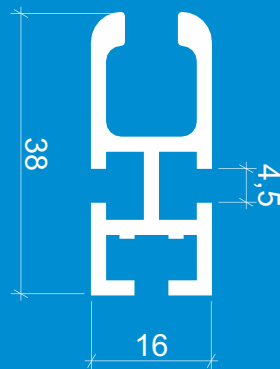

backlit



fabric



ELTEX KEDER Ø32

It is a perfect product for creating hanging constructions. The profile allows for suspension it under truss or ceiling. Due to strut system the construction looks very neat.

MATERIAL:
ALUMINUM ANODISED

COLOR:
NATURAL OR RAL

WEIGHT:
0,62 KG/R.M.

CATALOGUE NO.:
04.024

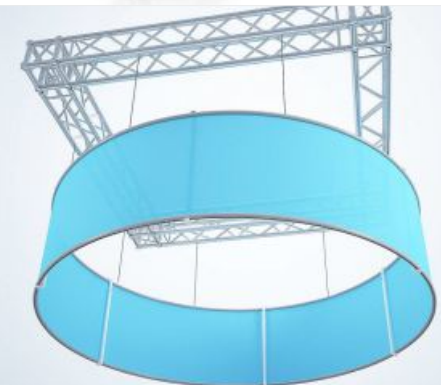
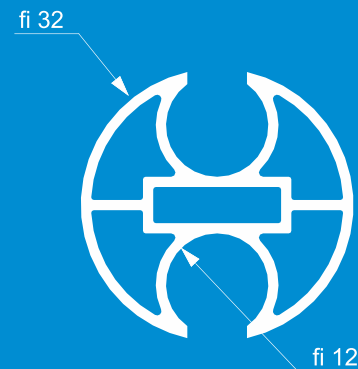

ELTEX KEDER Ø50

These profiles are mainly used for both straight and bent hanging constructions. When suspended, construction is most often used to create unique banners at exhibitions, especially when very light construction is required.

MATERIAL:
ALUMINUM ANODISED

COLOR:
NATURAL OR RAL

WEIGHT:
1,71 KG/R.M.

CATALOGUE NO.:
04.025

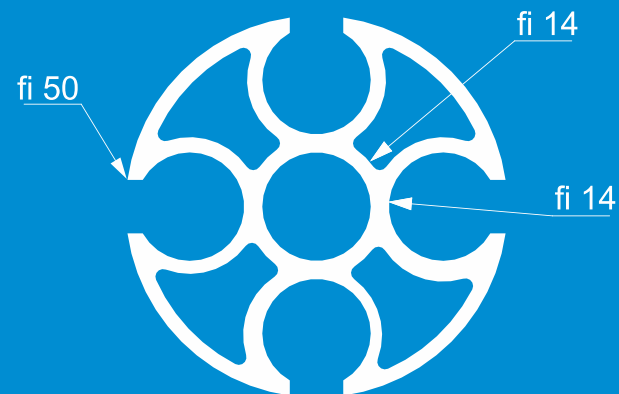

MX 80 EDGE

This profile is uniquely designed to screen aluminum support construction. The textile graphics match seamlessly in the corners. The ideal solution for creating freestanding exhibition stands. Together with the Eltex 80 EF and MX 80, the possibilities are unlimited.

MATERIAL:
ALUMINUM ANODISED

COLOR:
NATURAL OR RAL

WEIGHT:
2,43 KG/R.M.

CATALOGUE NO.:
02.012

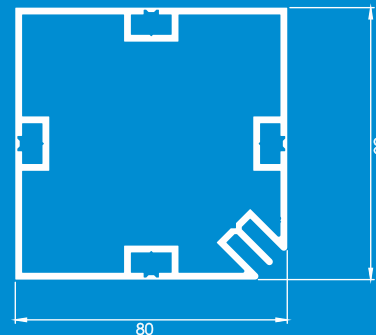



H PROFILE

This profile gives the option of toolless installation of shelves in stand or exhibition walls, with no damage to the textile or PVC graphics.

MATERIAL:
ALUMINUM ANODISED

COLOR:
NATURAL OR RAL

WEIGHT:
0,45 KG/R.M.

CATALOGUE NO.:
04.026

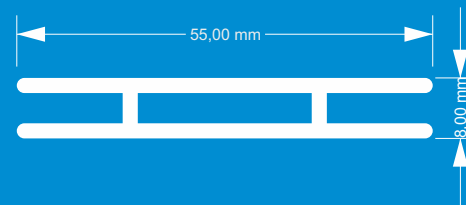



EDGE LED LIGHTING

The edge LED strips are fixed to the inside channel of the frame, so the light illuminates the textile graphics from the edge of the frame. The best match depends on the size of the frame, the depth of the profile, the angle of the light spreading.

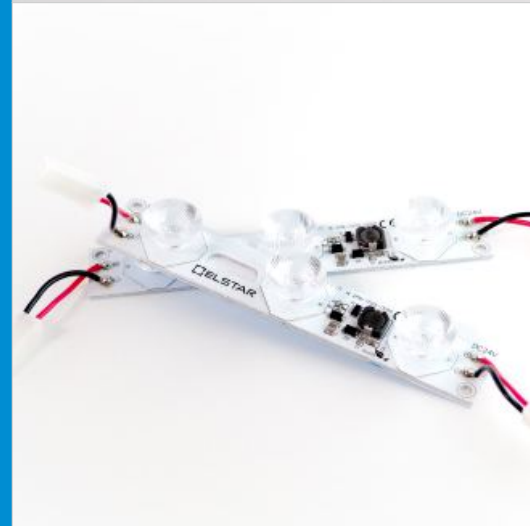



SURFACE LED LIGHTING

The surface LED strips are fixed to dibond on the back of the frame, so the light illuminates the textile graphics from the behind. The best effect is determined by the frames size, the profiles depth and the angle of light spreading.

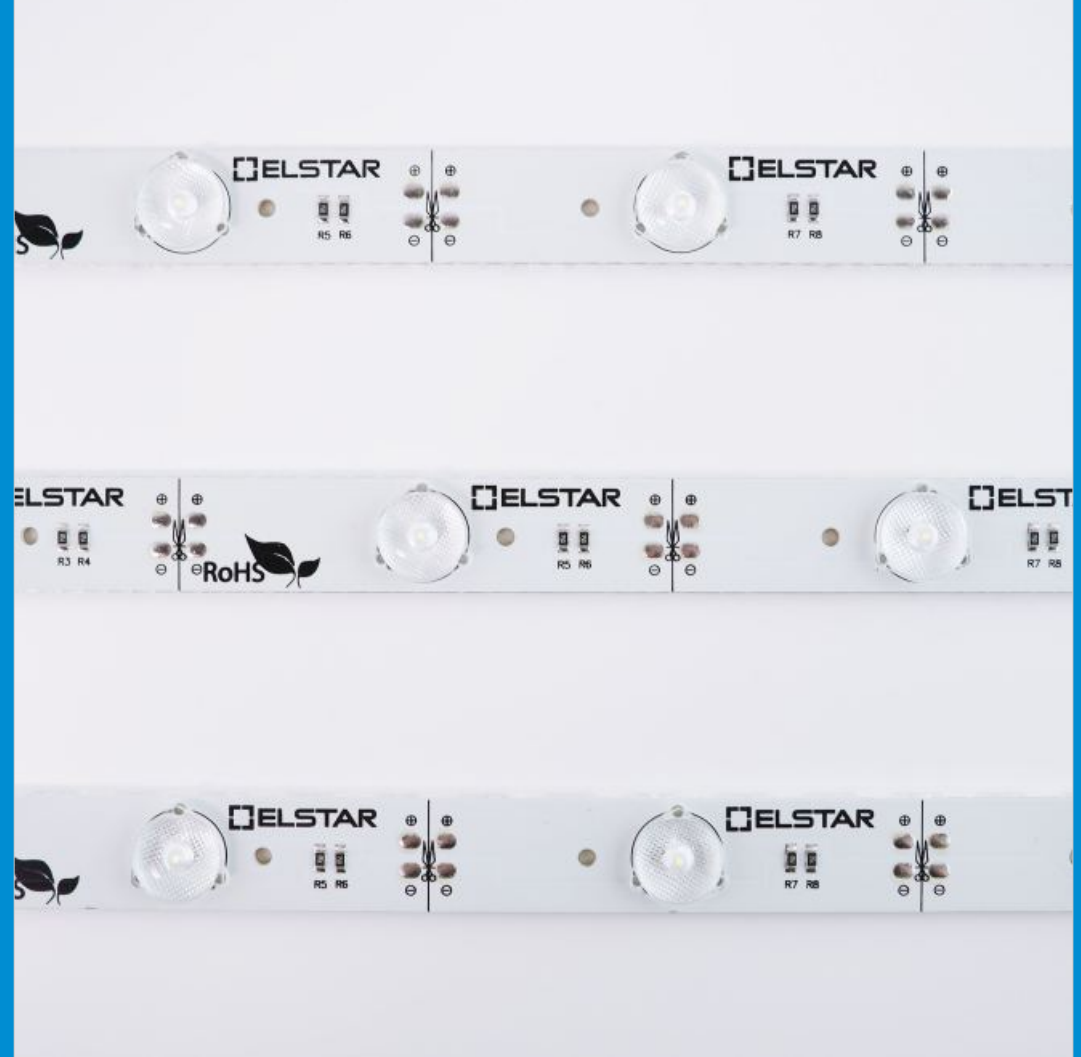

NEW profil

Eltex 15 light

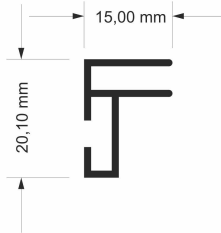

Description

This single-sided, most economic profile is widely used in retail & expo areas especially integrated into exhibition booths. Frames can be easily wall-mounted and the dimensions can be customized.

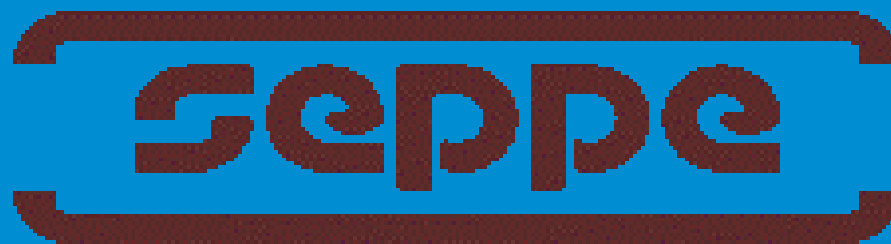

distributor profilů a rámců ELTEX

Seppe s.r.o.
Bohemia Business Park
Nádražní 334
Vráž u Berouna 267 11

TEL: +420 724 887 996